

C. A. MINERD.
RAIL JOINT.
APPLICATION FILED FEB. 21, 1905.

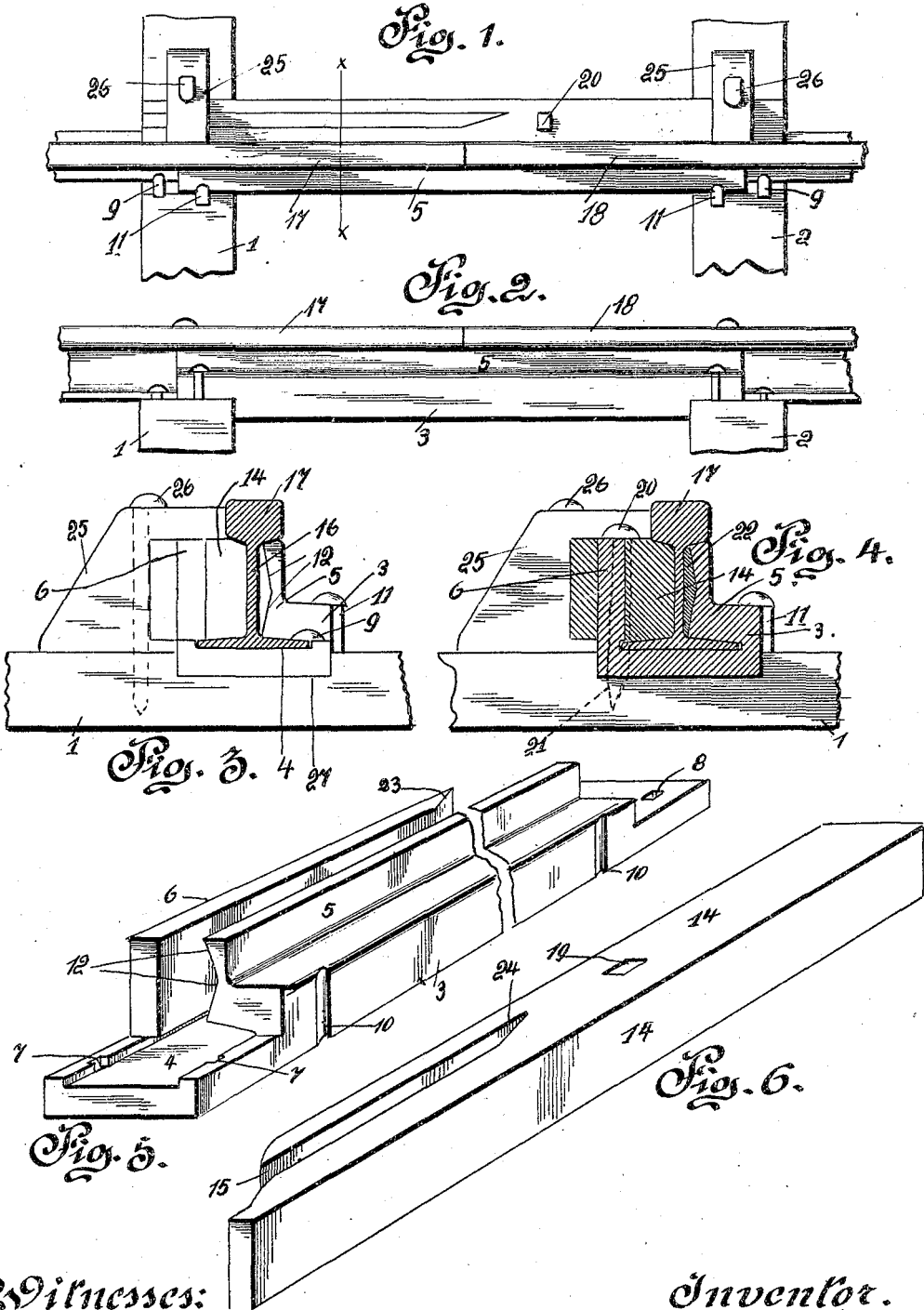

Witnesses:
C. Klostermann
A. H. Butler

Inventor.
Chas. A. Minerd.
By A. C. Ewert & Co.
Attorneys.

UNITED STATES PATENT OFFICE.

CHARLES A. MINERD, OF UNIONTOWN, PENNSYLVANIA.

RAIL-JOINT.

SPECIFICATION forming part of Letters Patent No. 788,928, dated May 2, 1905.

Application filed February 21, 1905. Serial No. 246,699.

To all whom it may concern:

Be it known that I, CHARLES A. MINERD, a citizen of the United States of America, residing at Uniontown, in the county of Fayette and State of Pennsylvania, have invented certain new and useful Improvements in Rail-Joints, of which the following is a specification, reference being had therein to the accompanying drawings.

This invention relates to certain new and useful improvements in rail-fasteners; and the invention has for its object to dispense with the use of nuts and bolts and employ novel means for securing the ends of two rail-sections together.

The invention aims to provide a novel form of chair adapted to be supported upon a suitable road-bed. In the chair I secure the confronting ends of two sections of rail by employing novel forms of fish-plates or spliced bars which are adapted to interlock with one another.

In connection with my improved rail-joint I employ novel means for bracing fish-plates employed in connection with my improved rail-joint.

The above construction, together with the details of construction, will be hereinafter more fully described and then specifically pointed out in the claims, and, referring to the drawings accompanying this application, like numerals of reference designate corresponding parts throughout the several views, in which—

Figure 1 is a top plan view of my improved rail-joint. Fig. 2 is a side elevation view of the same. Fig. 3 is an end view of my improved rail-joint. Fig. 4 is a transverse sectional view of the same. Fig. 5 is a perspective view of the chair, partly broken away; and Fig. 6 is a perspective view of a fish-plate or splice-bar employed in connection with my improved rail-joint.

In the accompanying drawings I have illustrated my improved rail-joint as being formed between two ties 1 and 2, and these ties are adapted to support the ends of a chair 3. The chair is clearly illustrated in Fig. 5 of the drawings, and by referring to this figure

it will be seen that the chair comprises a base portion 4, carrying a fish-plate 5, which is preferably formed integral with the base portion 4. The fish-plate 5 is formed upon one side of the chair, and diametrically opposed to said fish-plate is a brace-plate 6, which is also preferably formed integral, the entire chair being preferably formed of a casting. The ends of the base portion 4 of my improved chair extend beyond the fish-plate 5 and the brace-plate 6, and these ends are provided with apertures 7 7 and 8 8, whereby the chair can be secured, if desired, by spikes 9 to the ties 1 and 2. The one side of the chair is provided with vertically-disposed grooves 10 10, in which are adapted to engage spikes 11 11, employed for securing the chair to the ties 1 and 2. The inner face of the fish-plate 5 is provided with beveled faces 12 12, that converge toward one another. The object of these beveled faces will be presently described.

The reference-numeral 14 designates a fish-plate or splice-bar having a longitudinally-disposed slot 15 formed in its one end, and this slot is made of a sufficient width to permit of the fish-plate 14 being placed in engagement with the brace-plate 4. The side of the fish-plate 14 is adapted to engage the web portions 16 of the rails 17 and 18.

The reference-numeral 19 designates a vertically-disposed aperture formed in the fish-plate 14, and this aperture is employed in connection with a pin 20 for locking the fish-plate 14 in engagement with the chair 3, the base portion 4 of said chair being provided with an aperture 21 to receive the pin 20.

After the fish-plate 14 has been placed in engagement with the rails 17 and 18 a liner or splice-bar 22 is inserted between the web portions 16 of said rails and the converging beveled faces 12 of the plate 5. This liner firmly locks the rails 17 and 18 in engagement with the fish-plates 14 and 5, and the brace-plate 6 retains the fish-plate 14 in engagement with the web portions 16 of the rails 17 and 18. To facilitate the mounting of the fish-plate 14 upon the brace-plate 6, I have provided the brace-plate with a tapered end 23, which is

adapted to engage in the tapered end 24 of the slot 15.

In connection with the chair 3 and the fish-plates 14 and 5 I employ brackets 25 25, which are secured to the ties 1 and 2 by spikes 26 26. These brackets are adapted to overlies the brace-plate 6 and the fish-plate 14 and brace and steady the heads of the rails 17 and 18.

In the accompanying drawings I have illustrated the ties 1 and 2 as being cut away, as indicated at 27, to support the chair 3; but it will of course be understood that the ties can be sunk or depressed sufficiently to accommodate the chair in horizontal alinement with the rest of the road-bed without cutting away the ties.

The construction of my improved rail-joint permits of the rails 17 and 18 being firmly braced and secured together, forming practically a continuous tread upon the rails 17 and 18 for the rolling-stock, which passes over the same.

While I have herein shown the preferred manner of constructing my improved joint, it is obvious that various changes may be made in the details of construction without depart-

ing from the general spirit and scope of the invention.

What I claim, and desire to secure by Letters Patent, is—

1. In a rail-joint, the combination with two sections of rails, of a chair, a fish-plate carried by said chair, a brace-plate carried by said chair, a fish-plate adapted to engage said plate, brackets adapted to embrace said fish-plate and said brace-plate, and means to secure said plates and chair together, substantially as described.

2. In a rail-joint, the combination with two sections of rails, of a chair, a fish-plate carried by said chair, a brace-plate carried by said chair, a fish-plate adapted to embrace said brace-plate, a liner adapted to engage said rails and said fish-plate, brackets adapted to engage said chair and said fish-plate, means to secure said chair and said plates together, substantially as described.

In testimony whereof I affix my signature in the presence of two witnesses.

CHARLES A. MINERD.

Witnesses:

JNO. BOYLE,

O. P. MARKLE.